

3-A CERTIFIED SANITARY WELD-IN THERMOWELLS

JMS Southeast, Inc. is proud to be a US manufacturer of a full line of sanitary RTDs, thermocouples and thermowells (3-A Authorization #1482).

JMS Southeast's 3-A certified weld-in thermowells are designed to be used with either sanitary 3-A certified probes* or non-certified probes.** Sanitary thermowells should be welded to a tank or a vat with a full crevice-free fillet weld to avoid cracks and crevices. Standard sanitary weld-in wells are fabricated from stainless steel and then polished to a #4 finish.***

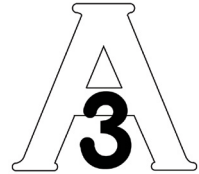

www.3-A.org

In addition to weld-in thermowells, JMS also offers a full line of 3-A certified sanitary cap thermowells. Illustrations of the most commonly selected cap styles can be found on page 4-2, row 8 of this catalog.

* For ordering and additional information, see pages 4-1 through 4-3 of this catalog.

** For thermocouples, please refer to section 1 of this catalog. For RTDs, please refer to section 3.

*** Other finishes available upon request to meet customer requirements.

#1	DESCRIPTION						
5C	3-A Certified sanitary thermowells - Add "W" here for a plug with a chain attached to well. (Example. 5CW)						
#2	U (INSERTION) DEPTH [15]						
U__"	Specify length in inches. Note: When specifying spring-loaded replacement sensor, customer should specify immersion length 1/4" shorter than the overall weld-in thermowell length						
#3	MATERIAL Note: see page 5-1 for more options.						
H I	304 SS 304L SS	K L	316 SS 316L SS	X	Other, specify		Note: When specifying an X, material selected must comply with 3-A standard, 74-03
#4	BORE SIZE & SENSOR CONNECTION insert 1/2" NPSM.						
2	.260" ID	3	.385" ID	X	Other, specify		Add "N" for FNPT (Example: 2N=FNPT)
#5	T (LAG) EXTENSION [5-15]						
Z	N/A (No Lag)			T__"	Specify length in inches		
#6	TAGGING OPTIONS						
1 X Z	Stamped on well (Standard) Other N/A						
#7	DOCUMENTATION & CERTIFICATIONS -- use all that apply (Example: "DU" requests dye penetrant test & X-Ray examination)						
M D P U W S	Material Test Reports (MTR) Dye penetrant testing Internal hydrostatic pressure test X-Ray examination Premium SwiftyCalc ASME 19.3TW calculation Surface finish certificate			E A N O	Certificate of electropolish Certificate of No Animal Derived Material (ADM) Certificate of no polishing compounds Certificate of cleaned for Oxygen service		

Note: Standard (sensor) connections are 1/2" FNPSM (female straight) to match 1/2" MNPT (male tapered)

Note: Does not include head and nipple. These parts may be ordered separately.

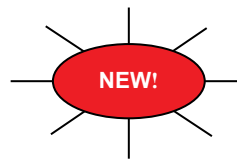
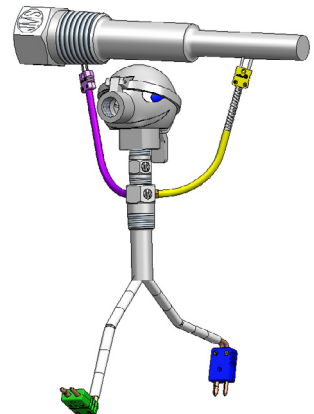
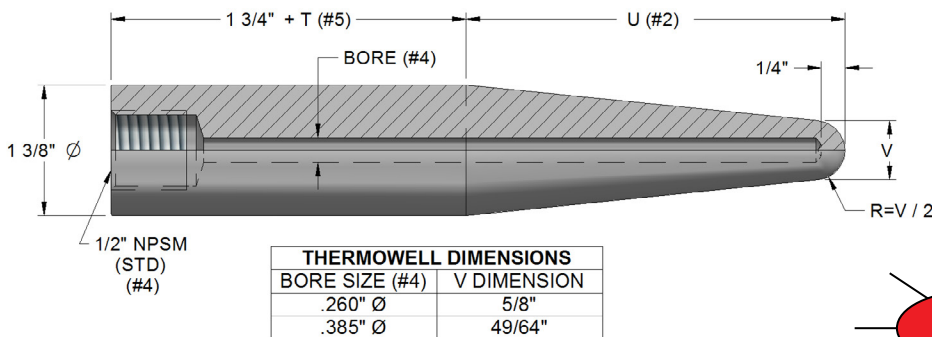

FREE Wake Frequency Calculations to ASME PTC 19.3 TW, **SwiftyCalc!** Visit JMS-SE.com to sign up today!
www.JMS-SE.com/SwiftyCalc