

GENERAL THERMOWELL INFORMATION

THERMOWELLS

Process Connection

Provides a means of mounting, supporting, and/or sealing the thermowell into the process system.

Types:

Threaded: Standard N.P.T.'s are 1/2", 3/4", and 1".

Socket Weld: Standard pipe sizes are 3/4" and 1" nominal. JMS socket wells are 3000lb rated. Other rating must be separately specified.

Flanged Welded: Large variety of flange sizes and pound ratings available.

Shank Construction

Straight: The outside diameter is the same size along the immersion length.

Step: The outside diameter at the end of the well is 1/2" to provide quicker response time.

Tapered: Used for high velocity applications. The outside diameter decreases gradually along the immersion length.

Q Dimension

The thickest part of the shank of the well on the hot side of the process connection or flange. Its dependent on the bore size and the process connection size.

Bore Size

The inside diameter of a thermowell. Standard bore sizes are .260 and .385.

Immersion ("U") Length

Immersion length of the thermowell. The "U" length is measured from the bottom of the process connection to the tip of the thermowell.

Lagging Extension ("T") Length

The lagging extension exists behind the process connection and is used to extend the hex length and enable the probe to extend through insulation or walls.

Note: Design program on page 5-17.

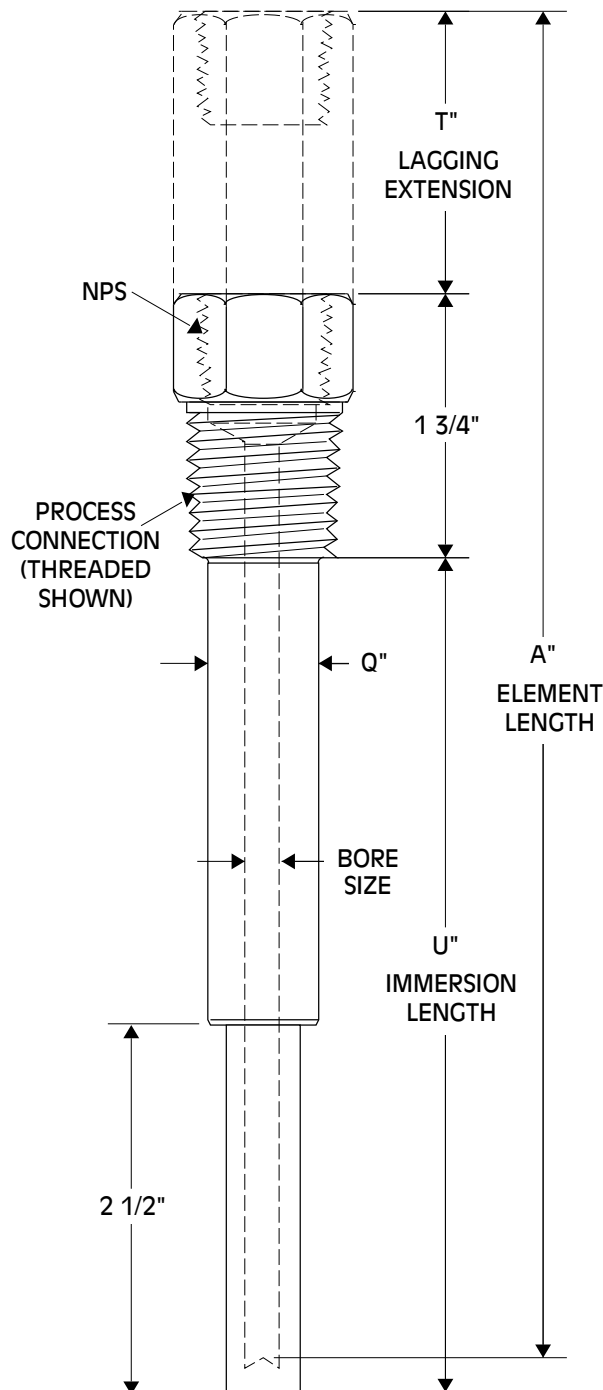

Note:

JMS has a complete design guide on disc for your use. Call and ask for the Thermowell Design Guide.