

INDUSTRIAL AND MINIATURE THERMOCOUPLES

#1	DESCRIPTION [6, 7]
1	Thermocouple
#2	TYPE [8,9,10]
—	J,T,K,E,N,X (Other, Specify)
#3	LIMITS OF ERROR/ELEMENT CONSTRUCTION
1	Standard Single 6 Standard Triple
2	Standard Dual X Other, specify
3	Special Single
4	Special Dual

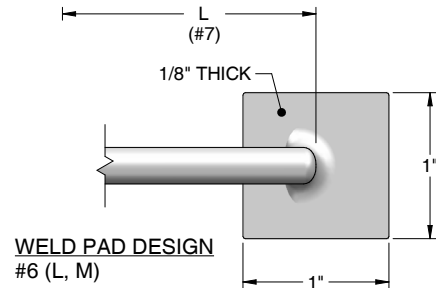

WELD PAD DESIGN
#6 (L, M)

Many more options available at JMS-SE.com

Note: For hollow tube sensors or sensors requiring a factory bend, see pages 2-1 and 2-2.

[] Brackets indicate page numbers where additional helpful information can be found in technical catalog. Now available online at www.JMS-SE.com/TechnicalCatalog

#4	OUTSIDE DIAMETER [1-11]	CONDUCTOR SIZE (FOR BASE METALS ONLY)									
		SINGLE (AWG)		DUAL (AWG)							
		OD	Single	Dual	OD	Single	Dual				
P	1/2"	10	12	R	6mm	16	18	F	1/25"	32	34
A	3/8"	13	16	C	3/16"	19	20	X*	Other, specify		
Y	5/16"	14	16	D	1/8"	22	24	*JMS now offers sheath as small as 0.010" diameter			
B	1/4"	16	18	E	1/16"	28	30				
#5	SHEATH MATERIAL [11]	MAX °F [2-8, 4-17]			MAX °F						
H	304 stainless steel	1650	C	Teflon coated stainless steel		400					
J	310 stainless steel	2100	S	Titanium		400					
V	STABALOY	2220	Q	Hastelloy C-276		800					
K	316 stainless steel	1650	P	Pyrosil		2300					
M	Inconel 600	2100	X	Other, specify		—					
#6	MEASURING JUNCTION [1-12, 13, 14, 15]										
G	Grounded	P	Reduced tip, grounded								
U	Ungrounded	Y	Reduced tip, ungrounded								
E	Exposed (isolated on dual/triple)	R	Gas/air, exposed								
I	Isolated	S	Gas/air, grounded								
J	Pointed tip, grounded 45°	T	Gas/air, ungrounded								
K	Pointed tip, ungrounded 45°	V*	Enlarged tip, grounded								
L	Weld pad, grounded (Flat)	W*	Enlarged tip, ungrounded								
M	Weld pad, ungrounded (Flat)	X	Other, specify								
N	Weld pad, removable grounded	*Provide length and enlarged diameter description when selecting these options.									
O	Weld pad, removable ungrounded	Note: For options N, NF, O, & OF Fastrax (aka removable weld pad) designs, refer to 4-11.									
NF	Removable, "foot" only, grounded										
OF	Removable, "foot" only, ungrounded										
#7	LENGTH (See illustrations on page 1-1 through 1-3 for lengths)										
—"	Length in Inches (Lengths greater than 90" may be coiled for shipment)										

REDUCED TIP DESIGN

#6 (P,Y)

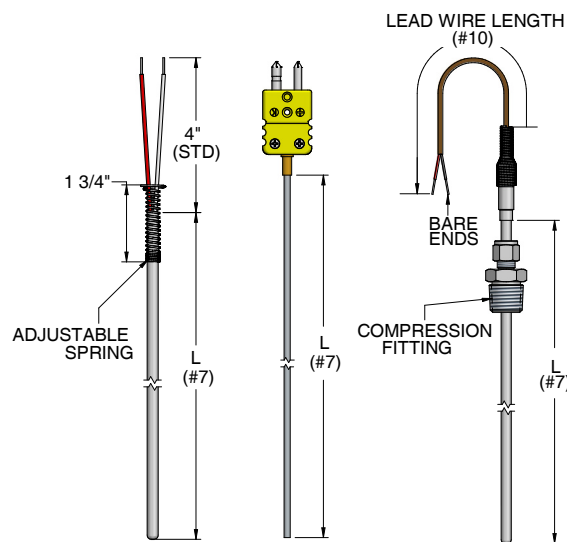
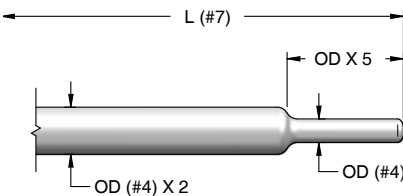

Note: L is the overall length of the sensor to the transition, wire, plug, head, or fixed attaching device. L excludes non-fixed attaching devices.

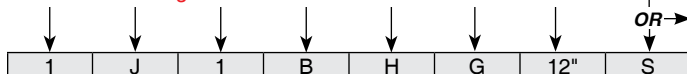

NEW Skip to page 1-3 to complete selection #8 if your sensor requires a nipple and/or union extension.

#8	STANDARD INDUSTRIAL ATTACHING DEVICE [1-3, 6-13]	
X	Other, specify	
Z	N/A	No attaching device
G	Single thread (process)	Welded design
F	Single thread (reversed)	
W	Double threaded	
H*	SS w/ SS ferrule	Compression design
I*	SS w/ Teflon ferrule	
J*	SS w/ Lava ferrule	
K*	SS w/ Nylon ferrule	
L*	Brass w/ Brass ferrule	
D	Single threaded (process)	Spring-loaded design
C	Double threaded w/ oil seal	
A	Double w/ threaded retainer	
E	Adjustable spring	
S	Double threaded (most common)	
B	Double threaded Bayonet	
BS*	Double threaded Bayonet w/ oil seal	
BD	Single threaded Bayonet	
BDS*	Single threaded Bayonet w/ oil seal	

Note: High nickel proprietary spring material is rated to 1000°F (for 1/4" Ø Sensors)

* Not recommended for sensors Ø > 1/4"



SEE PAGE 1-3

CUSTOM NIPPLE/UNION EXTENSION CONFIGURATOR

An extension assembly provides extra length extending the sensor head past insulation and away from heat. Standard unions are 1/2" FNPT on both ends. The union joins two nipples in an extension assembly and has a standard pressure rating of 150 PSIG.

When a nipple-union-nipple assembly is selected and spring-loading of the thermocouple element is required, there are two different methods of spring-loading the sensor. JMS's standard, recommended method is to use the machined 1/2" x 1/2" NPT spring-loaded stainless steel fitting as one of the nipples. With this design, the probe is secured within the fitting and mounted to the head in a rigid manner instead of spring-loading against a terminal block, as is the case with a standard nipple-union-nipple. Due to stress exerted by spring, selection #8, option N "nipple" should never be used with an in-head transmitter. Any of the other options within option #8 are compatible with in-head transmitters.

Notes:

- The standard JMS spring designed specifically for a 1/4" OD sensor is made of high nickel proprietary spring wire which allows users to successfully maintain 1/2" of spring-loading even up to 1000°F.
- Spring-loaded extension assemblies should not be used with ceramic protection tubes.

		#8	COLD SIDE STANDARD INDUSTRIAL ATTACHING DEVICE [1-3, 6-13]		
		X	Other, specify		<p>STANDARD ATTACHING DEVICE (ALREADY SELECTED IN #8)</p>
		Welded design	G	Single Thread (Process)	
		H2 I2 J2 K2 L2	Compression design SS w/ SS ferrule SS w/ Teflon ferrule SS w/ Lava ferrule SS w/ Nylon ferrule Brass w/ Brass ferrule		<p>MOST COMMON</p> <p>** L is the overall length of the sensor to the fixed attaching device. Page 1-1, selection #7 for T/Cs or 3-1, selection #6 for RTDs.</p>
		Spring-loaded design	D	Single threaded	
		U O X	#8.1 UNION Union Coupling Other, specify		<p>UNION (#8.1)</p> <p>Note: Thread adapters may be used when symbol #9 is not 1/2" NPT.</p>
		#8.2	PROCESS FITTING (MALE) N Nipple X Other, specify Z N/A (female thread)		
		" Z	#8.3 N LENGTH Specify (Inches)* N/A (female thread)		<p>* ONLY for configurations with nipples (option N for selection #8 or #8.2) ALL other configurations have fixed lengths and this selection is not applicable.</p>
		#8.4	UNION and/or NIPPLE MATERIAL H 304 stainless steel K 316 stainless steel C Black steel G Galvanized steel		
		1 2 3 X	#8.5 UNION PRESSURE RATING #150 - A351 spec (Standard) #3000 - A182 spec #6000 - A182 spec Other, specify		} ASTM
		S	U N 6" H 1		

Note: High nickel proprietary spring material is rated to 1000°F. (For 1/4" Ø sensors)

Continue on to the "PROCESS NPT" selection to finish creating your sensor part number. Selection #9 on page 1-2 (thermocouples) and 3-2 (RTDs).

ADDITIONAL TERMINATIONS

COLD END TERMINATION [SEE SECTION 6] Choose as many as applicable (**JMS part number prefixes are shown in parenthesis**)

Connectors	
<p style="text-align: center;">Plugs</p> <p>B Miniature plug (6A1B) BH Miniature high temperature plug (6A2B) <800°F C Standard plug (6A1C) F Standard high temperature plug (6A2C) <800°F WM Microphone style plug (6DA) WA Solid pin plug, heavy duty (6A3C) WC Jab in plug (6A4C) WE Ultra high temperature plug, glazed (6A5C) <1200°F WH Ultra high temperature plug, unglazed (6A7C) <1200°F WJ Low noise plug (6A6C) <425°F WL DIN-IEC microphone plug (6DB) V Molded/water resistant plug (6DC) Y M12 Male connector (6DY) WQ Miniature locking plug (6A8B2) WS Standard plug, locking (6A8C2)</p>	<p style="text-align: center;">Jacks</p> <p>D Miniature jack (6A1D) DH Miniature high temperature jack (6A2D) <800°F E Standard jack (6A1E) G Standard high temperature jack (6A2E) <800°F WF Microphone style jack (6DA) WB Solid pin jack, heavy duty (6A3E) WD Jab in jack (6A4E) WG Ultra high temperature jack, glazed (6A5E) <1200°F WI Ultra high temperature jack, unglazed (6A7E) <1200°F WK Low noise jack (6A6E) <425°F WN DIN-IEC microphone style jack (6DB) VF Molded/water resistant jack (6DC) YF M12 Female connector (6DY) WR Miniature locking jack (6A1DL2) WT Standard jack, locking (6A8E2)</p>

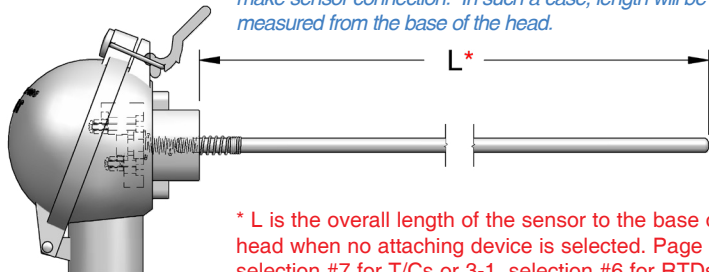
Heads [6-1] Visit www.JMS-SE.com/headspecs	
<p style="text-align: center;">Explosion Proof</p> <p>I Aluminum, NEMA 4X, FM, CSA, IP68 (6IA) J 316 stainless steel, NEMA 4X, FM, CSA, IP68 (6ISS) P Aluminum, NEMA 4X, FM, CSA, ATEX, IECEx, IP68 (6IAIEC) U 316 stainless steel, NEMA 4X, ATEX, IP68 (6ISSATEX) SI Cast Iron, NEMA 3, 4, UL, CSA (6I) GA Aluminum, screw cover w/ indicating window, NEMA 4X, ATEX, IECEx, FM, CSA, IP68 (688A1) GS 316SS, screw cover w/ indicating window, NEMA 4X, ATEX, IECEx, FM, CSA, IP68 (688S1)</p> <p style="text-align: center;">General Purpose</p> <p>L Aluminum w/ hinged cover (6L) M Aluminum w/ screw cover & chain (6M) R Aluminum w/ hinged high dome cover (6R) N Cast Iron w/ screw cover (6N) Q Black plastic (6Q) SS 316 stainless steel w/ screw cover & chain (6SS) WP White plastic, screw cover, Sanitary (6WP) SB Nickel plated, cylinder style, 1/4" NPT (6S250) SD Nickel plated, cylinder style, 1/8" NPT (6S125) SC Stainless steel, socket cap style ST Molded plastic, mini head, 1/4" NPT, < 350F (6T) SU Molded plastic, mini head, 1/4" NPT, < 800F (6U)</p>	<p style="text-align: center;"><i>Some applications may have pre-existing threaded pipes or protection tubes where no attaching device is needed to make sensor connection. In such a case, length will be measured from the base of the head.</i></p>  <p style="text-align: center;">* L is the overall length of the sensor to the base of the head when no attaching device is selected. Page 1-1, selection #7 for T/Cs or 3-1, selection #6 for RTDs.</p>

Transmitters [8-1 to 8-3]			
Notes: - Add span range after transmitter selection. Example: 8H(0-200C). - Transmitter output = 4 - 20 mA. (See section 8 for other options).			
8H	Isolated transmitter	8PA	Explosion proof, IP66/IP68, NEMA 4X, ATEX/IECEx, FM/CSA, Aluminum, threaded cap with glass viewing window, touch programmable [8-2]
8N	Non-isolated transmitter		
8I	Hart Protocol	8PS	Explosion proof, IP66/IP68, NEMA 4X, ATEX/IECEx, FM/CSA, 316 SS, threaded cap with glass viewing window, touch programmable [8-2]
8E	Intrinsically safe		
8D	Hart/Intrinsically safe		
8M	Integral transmitter (see page 3-5)		RTDs ONLY

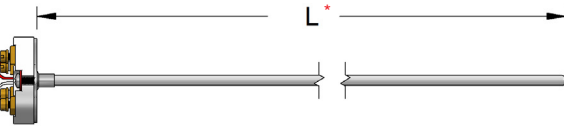
Other	
<p>A Bare ends K Spade lugs (6SL) RL Ring lugs (6RL) O Open ceramic terminal block, brass screw terminal (6B) OA Open Bakelite terminal block, nickel plated screw terminal (6BB) OB Open ceramic terminal block for sensors with bayonet style connection, brass screw terminal (6B or 6C) OG Ceramic terminal block, brass screw terminal (6G) OP Pluggable polyimide terminal block, nickel plated screw terminal (6PT) OS Open ceramic terminal block, nickel plated solder terminal (6C) CG Cord connector/grip, aluminum 1/2" NPT (6CC) TB Conduit bushing, 3/4" NPT male X 1/2" NPT female, plated steel (6IRB) X Other, specify</p>	 <p style="text-align: center;">* L is the overall length of the sensor to the base of the terminal block mounting plate when open terminal block cold end termination is selected without a fixed attaching device. Page 1-1, selection #7 for T/Cs or 3-1, selection #6 for RTDs.</p>