

RESTRICTION ORIFICE PLATES (NO BEVEL)

RESTRICTION ORIFICE PLATES

Whether the need is to build back pressure for a pump or reduce the flowing pressure downstream, Restriction Orifice Plates are excellent solutions for flow control applications where flow measurement is not needed.

Non-beveled edges along the inside bore diameter optimize use of Restriction Orifice Plates for two way flow. These plates are often subjected to severe flow conditions associated with large pressure reductions and the related fluid conditions caused by liquids flashing to a gas, cavitation and choked flow. Thicker edges mean more lifespan for the same cost!

Restriction orifice plates are offered in standard and custom dimensions, standard and exotic materials. Coatings are available. We can and will build to your specification!

PLATE STYLE "R"

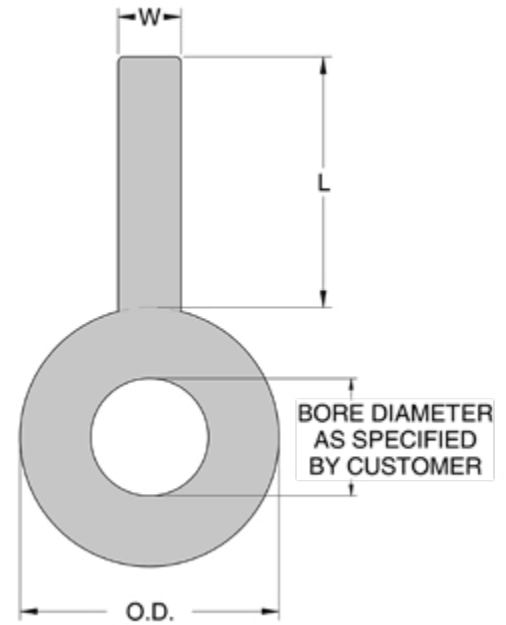

FLOW TYPE ORIFICE PLATES (BEVELED BORE)

PLATE STYLE "F"

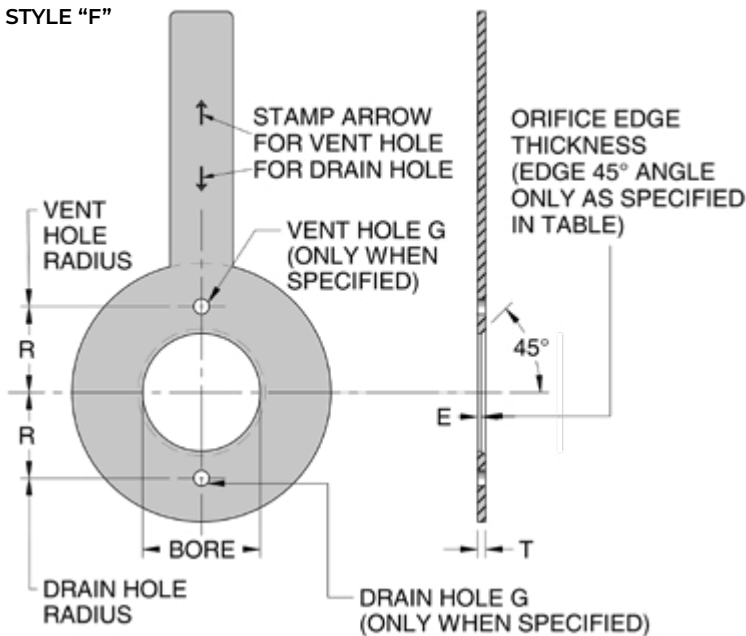

FLOW ORIFICE PLATES

Flow Type Orifice Plates are excellent solutions for reducing the pipe diameter to enable precise flow calculations. They also save you money by reducing the flowing pressure and demand on downstream flow system components. Flow Type Orifice Plates are available in standard and custom dimensions, standard and exotic materials. Flow calculations per AGA, ISO and ASME are available upon request.

TABLE 1

Line Pipe Size	Orifice Edge Thickness E
1/2" — 1-1/2"	1/64"
2" — 3"	1/32"
3-1/2" — 6"	1/16"
8" — 12"	1/8"
4" — 36"	1/8"

ORDERING SPECIFICATIONS

WHEN ORDERING PLEASE SPECIFY:

- Plate Style *(See Figure 1)*
- Line Size & Pressure Rating (#) *(Table 2)*
- Material
- Quantity *(Table 2)*
- Plate Thickness (T) *(Figure 2)*
- Bore Location & Diameter *(Figure 2)*

MATERIAL OPTIONS

- 316/316L Stainless Steel
- 304/304L Stainless Steel
- 321 Stainless Steel
- I600 Stainless Steel
- Carbon Steel
- Duplex 2205 Stainless Steel
- Monel 400
- Hastelloy C276
- Titanium Grade 2
- Tantalum
- Many more!

TABLE 2

STANDARD DIMENSIONS													
Line Size	150#	300#	600#	900#	1500#	All Ratings			Weight in pounds - Blank Plate				
	O.D.	O.D.	O.D.	O.D.	O.D.	T	W	L	150#	300#	600#	900#	1500#
1/2"	1.875	2.125	2.125	2.500	2.500	0.125	1.00	4.00	.2	.2	.2	.3	.3
3/4"	2.250	2.625	2.625	2.750	2.750	0.125	1.00	4.00	.3	.3	.3	.3	.3
1"	2.625	2.875	2.875	3.125	3.125	0.125	1.00	4.00	.3	.4	.4	.5	.5
1-1/2"	3.375	3.750	3.750	3.875	3.875	0.125	1.00	4.00	.5	.5	.5	.6	.6
2"	4.125	4.375	4.375	5.625	5.625	0.125	1.00	4.00	.6	.7	.7	1.0	1.0
2-1/2"	4.875	5.125	5.125	6.500	6.500	0.125	1.00	4.00	.8	.9	.9	1.3	1.3
3"	5.375	5.875	5.875	6.625	6.875	0.125	1.00	4.00	1.0	1.1	1.1	1.4	1.5
4"	6.875	7.125	7.625	8.125	8.250	0.125	1.00	4.00	1.5	1.6	1.8	2.0	2.1
5"	7.750	8.500	9.500	9.750	10.000	0.125	1.00	5.00	1.9	2.2	2.7	2.9	3.0
6"	8.750	9.875	10.500	11.375	11.125	0.125	1.00	5.00	2.4	3.0	3.4	3.9	3.7
8"	11.000	12.125	12.625	14.125	13.875	0.125	1.00	5.00	3.6	4.4	4.8	5.9	5.7
10"	13.375	14.250	15.750	17.125	17.125	0.125	1.00	5.00	5.3	6.0	7.3	8.6	8.6
12"	16.125	16.625	18.000	19.625	20.500	0.250	1.25	5.00	8.1	8.6	10.0	11.7	12.8
14"	17.750	19.125	19.375	20.500	—	0.250	1.25	5.00	11.0	11.7	13.0	14.2	—
16"	20.250	21.250	22.250	22.625	—	0.250	1.25	5.00	11.9	13.1	14.4	14.8	—
18"	21.625	23.500	24.125	25.125	—	0.250	1.25	5.00	27.5	32.3	34.0	36.8	—
20"	23.875	25.750	26.875	27.500	—	0.250	1.25	5.00	33.3	38.6	42.0	43.9	—
24"	28.250	30.500	31.125	33.000	—	0.250	1.25	5.00	47.2	53.9	56.0	62.9	—

Plates fit ANSI flanges up to 24". Orifice plates for line sizes larger than 24" are available. Consult factory for dimensions.

TABLE 3

ORIFICE BORE DIMENSIONAL TOLERANCES	
Orifice Bore	Plus or Minus Tolerances
Less Than 0.250"	0.001
0.250" to 0.499"	0.001
0.500" to 1.999"	0.0010
2.000" to 3.999"	0.0015
4.000" to 9.999"	0.0020
10.000" to 19.999"	0.0050
20.000 & up	0.0100

TABLE 4

STANDARD VENT AND DRAIN HOLE SIZE	
Orifice Bore	Vent or Drain Hole G
Less Than 1.000"	None
1.000 to 3.500"	3/32"
3.501 to 4.125"	1/8"
4.126 to 5.000"	5/32"
5.001 to 6.000"	3/16"
6.001 to 6.750"	7/32"
6.751 to 7.500"	1/4"
7.501 to 8.375"	9/32"
8.376 to 9.250"	5/16"
9.251 to 10.000"	11/32"
10.001 to 10.875"	3/8"
10.876 to 11.625"	13/32"
11.626 to 12.500"	7/16"
12.501 to 13.250"	15/32"
13.251 & Larger	1/2"

ORIFICE PLATES

#1	DESCRIPTION	
8P	PADDLE ORIFICE PLATES	
#2	PLATE STYLE (See Figure 1)	
R	Restriction (No Bevel)	
F	Bevelled Bore	
Q	Quadrant Edge Bore	
O	Orifice Seal (No Bore)	
#3	MATERIAL	
G	Carbon Steel A516Gr70	
X	Duplex F51/2205	
I	304/304L	
L	316/316L	
X	321	
M	Alloy 600	
N	Alloy 400	
X	Alloy 20	
S	Tit Gr2	
Q	Alloy C-276	
X	Other, specify	

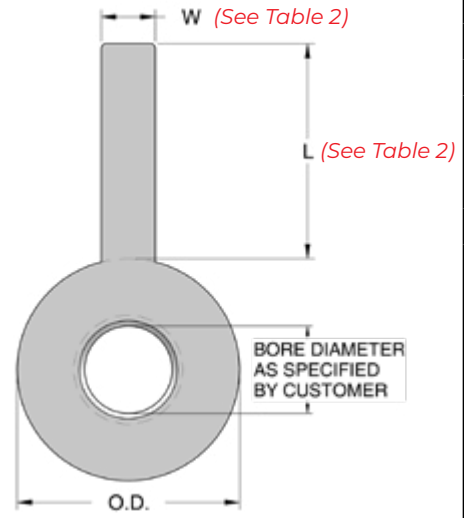

Not enough options?
Custom designs also available by drawing!

#4	LINE SIZE (See Tables 1 & 2)	
05	1/2"	12
075	3/4"	14
1	1"	16
15	1-1/2"	18
2	2"	20
25	2-1/2"	24
3	3"	26
4	4"	28
6	6"	30
8	8"	X
10	10"	Other, Specify

#5	BORE LOCATION (See Figure 2)	
C	Concentric	
E	Eccentric*	
S	Segmental*	
X	Other, specify	
Z	Not Applicable (Standard for Orifice Seal)	

**Note: Bevel not standard for these options. Call out with "X" if Bevel required.*

#6	BORE DIAMETER (See Table 3)
__"	Specify

(Figure 1) PLATE STYLE

(Figure 2) BORE LOCATION

#7	RATING & FACE STYLE (See Table 2)
A	150#
B	300#
D	600#
E	900#
F	1500#
G	2500#
X	Other, specify

Note: If RTJ style needed add R suffix. (example: GR = 2500# Ring Joint Style)

#8	PLATE THICKNESS (T) in inches
T	Standard T (from Table 2)
T_"	Other, specify

#9	OPTIONS (Use only if applicable.)
V	Vent (from Table 4)
D	Drain (from Table 4)
C	CRN
W	Calculation
M	MTR
Z	No Paddle
A	Tag # Stamped

8P F L 6 C 1" B T VM