

WIRE, GASKET, AND LUG THERMOCOUPLES

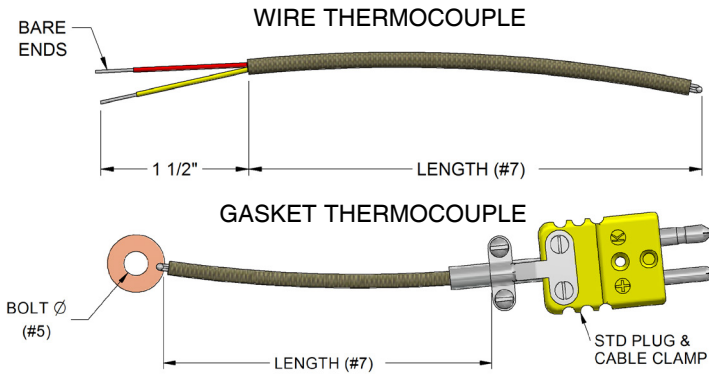

RING TERMINAL THERMOCOUPLE

SPADE LUG THERMOCOUPLE

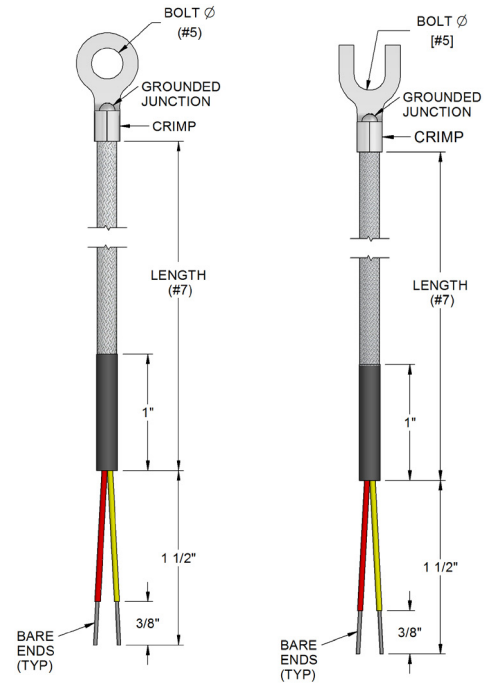

#1	DESCRIPTION
1D	Wire gasket and lug thermocouples - Grounded
#2	STYLE
G	Wire thermocouple
H	Gasket thermocouple
L	Ring terminal thermocouple
S	Spade lug thermocouple
M*	Shim thermocouple
C**	Hose clamp thermocouple

* Must select option 8" from selection #6
 ** See hose clamp dimensional chart below to specify needed clamp size by adding the corresponding # as a suffix.
 Example C2 = Hose clamp T/C to fit 1/2" - 3/4" pipe

#3	TYPE
---	J, K, N, T, E, R, S, B, C, L, A, X (Other, specify)
#4	GASKET MATERIAL
C	Copper (Standard)
S*	Steel
X	Other, specify
Z	N/A

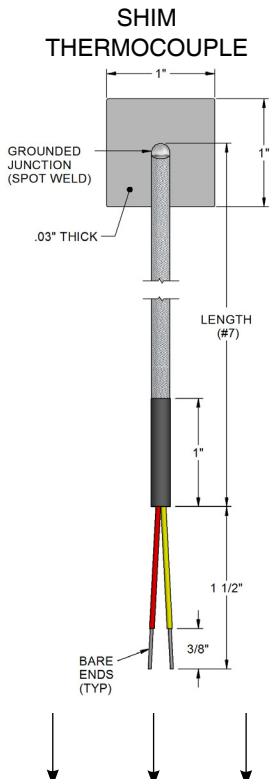

#5	BOLT DIAMETER
A	#10 (13/64" ID)
C	1/4" (9/32" ID)
X	Other, specify bolt size, ID, OD, thickness, and any tolerances as necessary.
Z	N/A
P	Spark plug washer

* Standard material for ring/spade lugs is nickel-plated steel.
 Gasket, shim and hose clamp Stainless Steel.

#6	WIRE INSULATION
1	Fiberglass braid
3	FEP Teflon
4	Hi-temp fiberglass braid
5	Kapton
8	Fiberglass braid/stainless steel overbraid
X	Other, specify

Note: For stranded wire, add an S prefix before symbol designation in this column. 24 AWG or smaller may be used to accommodate some smaller diameters.

#7	LENGTH
---	Length in inches
#8	COLD END TERMINATION
A	Bare ends
B	Miniature plug [Additional options available. See page 1-7]
C	Standard plug
X	Other, specify

#9	OPTIONS (See page 1-2, Options #14)
----	-------------------------------------

HOSE CLAMP DIMENSIONAL CHART

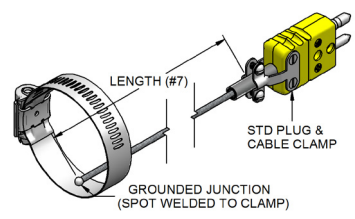

	STANDARD PIPE SIZE (INCHES)	HOSE CLAMP ID (INCHES)	
		MIN.	MAX.
1	1/4 to 3/8	7/16	25/32
2	1/2 to 3/4	11/16	1-1/4
3	1 to 1-1/2	1-1/16	2
4	2 to 2-1/2	2-1/16	3
5	3 to 3-1/2	3-5/16	4-1/4
6	4	3-9/16	4-1/2
7	5	5-1/8	6
8	6	6-1/8	7
X	Other Specify		

1D	G	K	Z	Z	1	36"	C
----	---	---	---	---	---	-----	---

ADDITIONAL TERMINATIONS

COLD END TERMINATION [SEE SECTION 6] Choose as many as applicable (JMS part number prefixes are shown in parenthesis)

Connectors	
<p style="text-align: center;">Plugs</p> <p>B Miniature plug (6A1B) BH Miniature high temperature plug (6A2B) <800°F C Standard plug (6A1C) F Standard high temperature plug (6A2C) <800°F WM Microphone style plug (6DA) WA Solid pin plug, heavy duty (6A3C) WC Jab in plug (6A4C) WE Ultra high temperature plug, glazed (6A5C) <1200°F WH Ultra high temperature plug, unglazed (6A7C) <1200°F WJ Low noise plug (6A6C) <425°F WL DIN-IEC microphone plug (6DB) V Molded/water resistant plug (6DC) Y M12 Male connector (6DY) WQ Miniature locking plug (6A8B2) WS Standard plug, locking (6A8C2)</p>	<p style="text-align: center;">Jacks</p> <p>D Miniature jack (6A1D) DH Miniature high temperature jack (6A2D) <800°F E Standard jack (6A1E) G Standard high temperature jack (6A2E) <800°F WF Microphone style jack (6DA) WB Solid pin jack, heavy duty (6A3E) WD Jab in jack (6A4E) WG Ultra high temperature jack, glazed (6A5E) <1200°F WI Ultra high temperature jack, unglazed (6A7E) <1200°F WK Low noise jack (6A6E) <425°F WN DIN-IEC microphone style jack (6DB) VF Molded/water resistant jack (6DC) YF M12 Female connector (6DY) WR Miniature locking jack (6A1DL2) WT Standard jack, locking (6A8E2)</p>

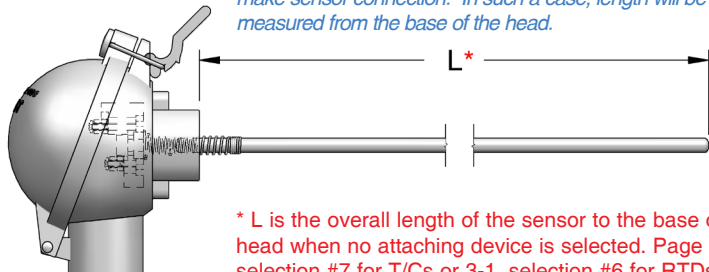
Heads [6-1] Visit www.JMS-SE.com/headspecs	
<p style="text-align: center;">Explosion Proof</p> <p>I Aluminum, NEMA 4X, FM, CSA, IP68 (6IA) J 316 stainless steel, NEMA 4X, FM, CSA, IP68 (6ISS) P Aluminum, NEMA 4X, FM, CSA, ATEX, IECEx, IP68 (6IAIEC) U 316 stainless steel, NEMA 4X, ATEX, IP68 (6ISSATEX) SI Cast Iron, NEMA 3, 4, UL, CSA (6I) GA Aluminum, screw cover w/ indicating window, NEMA 4X, ATEX, IECEx, FM, CSA, IP68 (688A1) GS 316SS, screw cover w/ indicating window, NEMA 4X, ATEX, IECEx, FM, CSA, IP68 (688S1)</p> <p style="text-align: center;">General Purpose</p> <p>L Aluminum w/ hinged cover (6L) M Aluminum w/ screw cover & chain (6M) R Aluminum w/ hinged high dome cover (6R) N Cast Iron w/ screw cover (6N) Q Black plastic (6Q) SS 316 stainless steel w/ screw cover & chain (6SS) WP White plastic, screw cover, Sanitary (6WP) SB Nickel plated, cylinder style, 1/4" NPT (6S250) SD Nickel plated, cylinder style, 1/8" NPT (6S125) SC Stainless steel, socket cap style ST Molded plastic, mini head, 1/4" NPT, < 350F (6T) SU Molded plastic, mini head, 1/4" NPT, < 800F (6U)</p>	<p style="text-align: center;"><i>Some applications may have pre-existing threaded pipes or protection tubes where no attaching device is needed to make sensor connection. In such a case, length will be measured from the base of the head.</i></p>  <p style="text-align: center;">* L is the overall length of the sensor to the base of the head when no attaching device is selected. Page 1-1, selection #7 for T/Cs or 3-1, selection #6 for RTDs.</p>

Transmitters [8-1 to 8-3]			
Notes: - Add span range after transmitter selection. Example: 8H(0-200C). - Transmitter output = 4 - 20 mA. (See section 8 for other options).			
8H	Isolated transmitter	8PA	Explosion proof, IP66/IP68, NEMA 4X, ATEX/IECEx, FM/CSA, Aluminum, threaded cap with glass viewing window, touch programmable [8-2]
8N	Non-isolated transmitter		
8I	Hart Protocol	8PS	Explosion proof, IP66/IP68, NEMA 4X, ATEX/IECEx, FM/CSA, 316 SS, threaded cap with glass viewing window, touch programmable [8-2]
8E	Intrinsically safe		
8D	Hart/Intrinsically safe		
8M	Integral transmitter (see page 3-5)		RTDs ONLY

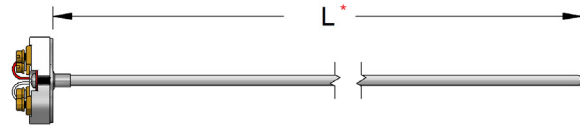
Other	
<p>A Bare ends K Spade lugs (6SL) RL Ring lugs (6RL) O Open ceramic terminal block, brass screw terminal (6B) OA Open Bakelite terminal block, nickel plated screw terminal (6BB) OB Open ceramic terminal block for sensors with bayonet style connection, brass screw terminal (6B or 6C) OG Ceramic terminal block, brass screw terminal (6G) OP Pluggable polyimide terminal block, nickel plated screw terminal (6PT) OS Open ceramic terminal block, nickel plated solder terminal (6C) CG Cord connector/grip, aluminum 1/2" NPT (6CC) TB Conduit bushing, 3/4" NPT male X 1/2" NPT female, plated steel (6IRB) X Other, specify</p>	 <p style="text-align: center;">* L is the overall length of the sensor to the base of the terminal block mounting plate when open terminal block cold end termination is selected without a fixed attaching device. Page 1-1, selection #7 for T/Cs or 3-1, selection #6 for RTDs.</p>